

#### Specifications :

#### ICE 15RF

Eccentric moment	0-14,7 kgm	<b>Clamps:</b>	
Max. centrifugal force	0-870 kN	Sheet pile clamp	130TU
Max. frequency	2300 rpm	Transport weight per piece	610 kg
Max. amplitude excl. 130TU	12,6 mm	Double clamps	55TC
Max. amplitude incl. 130TU	10,7 mm	Transport weight per piece	310 kg
Max. static line-pull	270 kN		
Max. pull-down	120 kN		
Max. operating pressure	350 bar	<b>Powerpack:</b>	
Max. oil flow	340 l/min	Model	400 series
Max. hydraulic power	198/269 kW/HP		
Forced lubrication	yes		
Dynamic weight excl. 130TU	2130 kg	<b>Hose set:</b>	
Dynamic weight incl. 130TU	2740 kg	Length	30 m
Total weight excl. 130TU & hoses	2900 kg	Transport weight (±)	615 kg

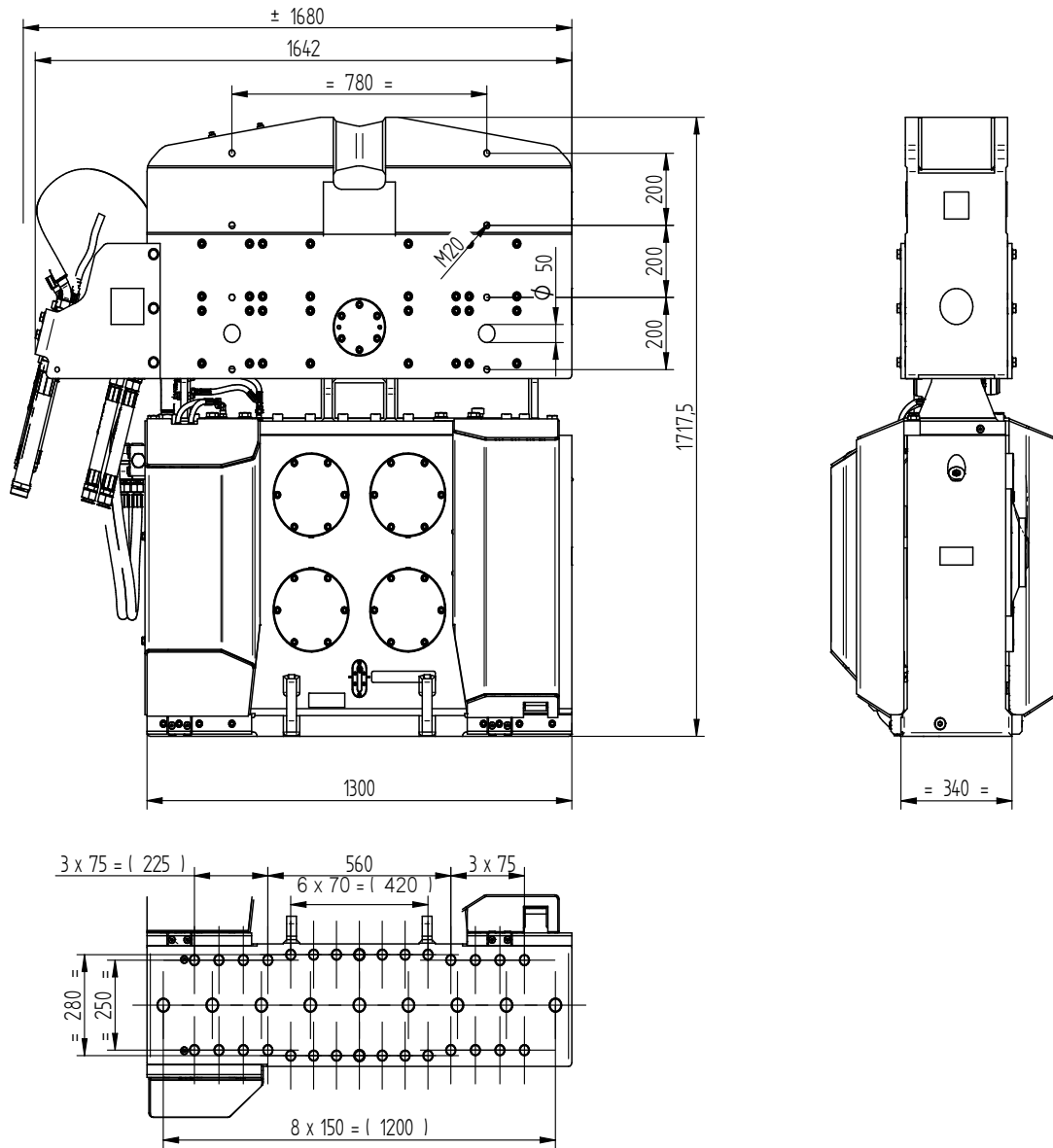

#### Technische Daten :

#### ICE 15RF

Statisches Moment	0-14,7 kgm	<b>Klemmzange:</b>	
Max. Fliehkraft	0-870 kN	Universalzange	130TU
Max. Drehzahl	2300 rpm	Transportgew. pro Stück	610 kg
Max. Amplitude ohne 130TU	12,6 mm	Rohrklemmzange	55TC
Max. Amplitude mit 130TU	10,7 mm	Transportgew. pro Stück	310 kg
Max. Statische Zugkraft	270 kN		
Max. Vorspannung	120 kN		
Max. Betriebsdruck	350 bar	<b>Aggregat:</b>	
Max. Fördermenge	340 l/min	Modell	400 series
Max. hydraulische Leistung	198/269 kW/PS		
Zwangsschmierung	ja		
Dyn. Gewicht ohne 130TU	2130 kg	<b>Schlauchsatz:</b>	
Dyn. Gewicht mit 130TU	2740 kg	Länge	30 m
Gesamtgew. Ohne 130TU & Schläuche	2900 kg	Transportgewicht (±)	615 kg

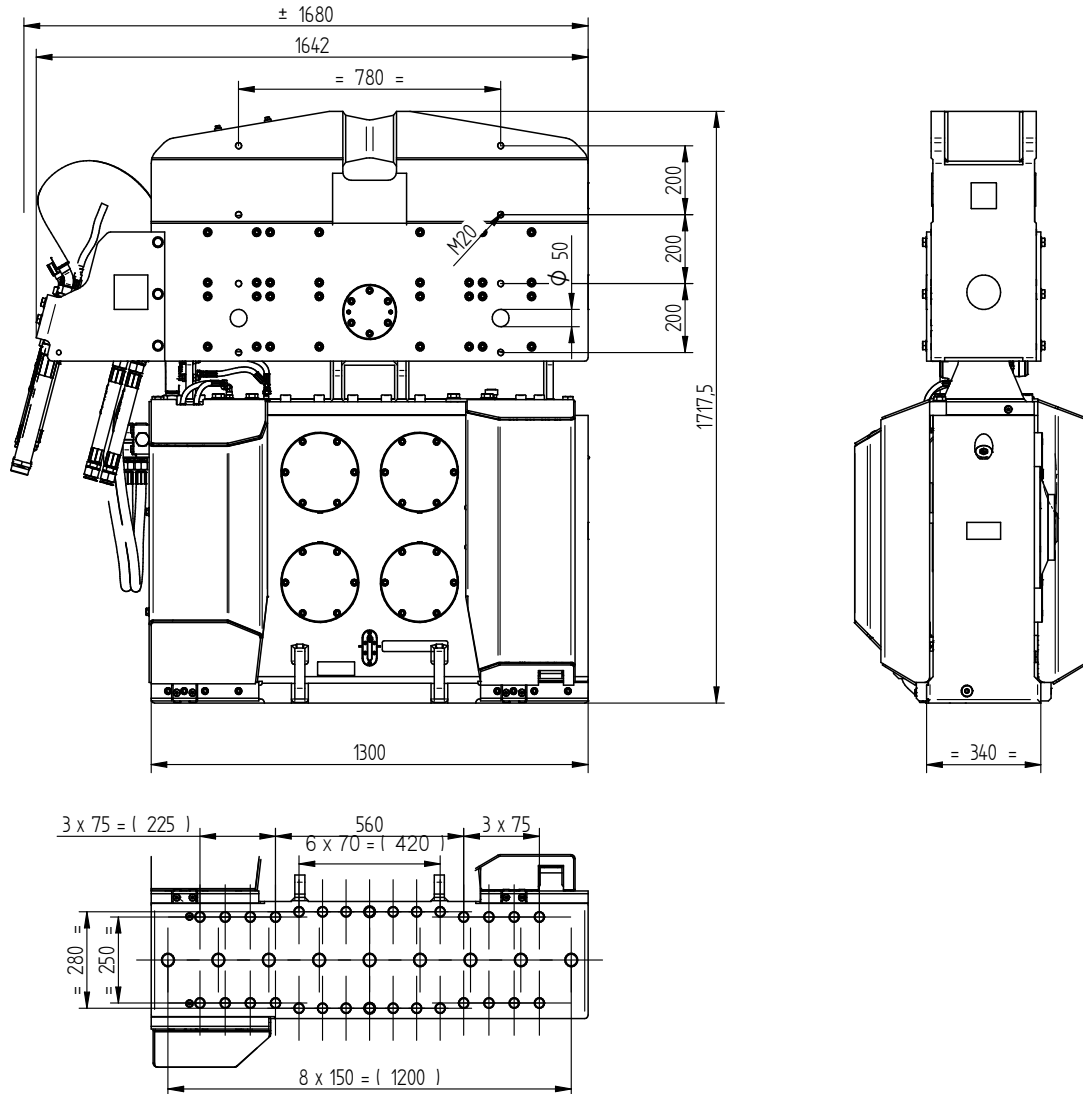

Spécifications		ICE 15RF	
Moment excentrique	0-14,7 kgm	<b>Pinces:</b>	
Max. force centrifuge	0-870 kN	Pince palplanche	130TU
Max. fréquence	2300 rpm	Poids de transport par pièce	610 kg
Max. amplitude sans 130TU	12,6 mm	Pince tube	55TC
Max. amplitude avec 130TU	10,7 mm	Poids de transport par pièce	310 kg
Force de traction statique	270 kN		
Force maximale d'appui	120 kN		
Pression de travail max.	350 bar	<b>Groupe hydraulique:</b>	
Débit d'huile max.	340 l/min	Modèle	400 series
Puissance hydraulique max.	198/269 kW/ch		
Huile lubrifiante	oui		
Poids dynamique sans 130TU	2130 kg	<b>Jeu de tuyau:</b>	
Poids dynamique avec 130TU	2740 kg	Longueur	30 m
Poids total sans 130TU & tuyaux	2900 kg	Poids de transport (±)	615 kg

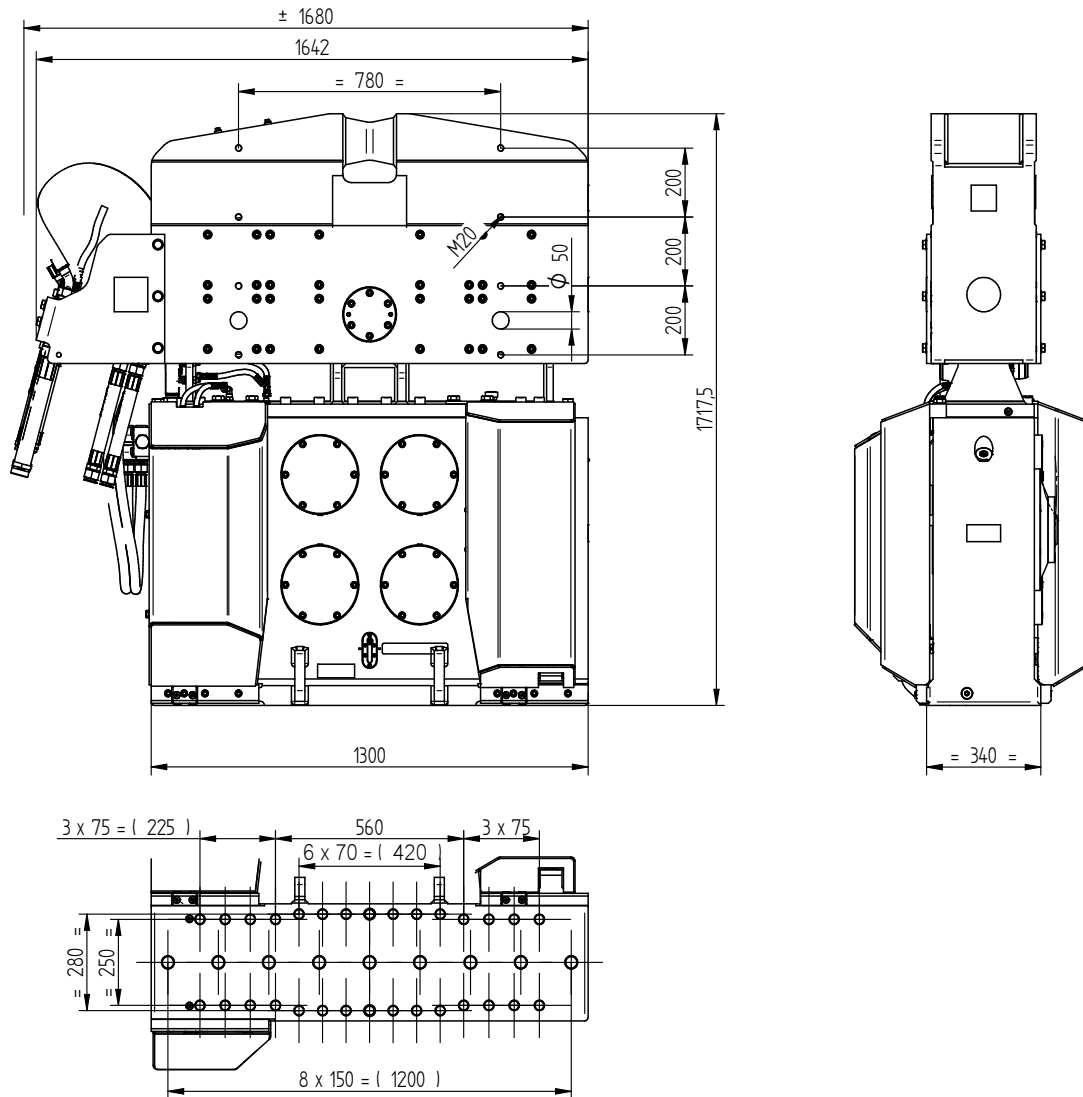

## Specificaties

## ICE 15RF

Excentrisch moment	0-14,7 kgm	<b>Klemmen:</b>	
Max. centrifugaalkracht	0-870 kN	Damwandklem	130TU
Max. toerental	2300 rpm	Transportgewicht per klem	610 kg
Max. amplitude excl. 130TU	12,6 mm	Pijpenklem	55TC
Max. amplitude incl. 130TU	10,7 mm	Transportgewicht per klem	310 kg
Max. statische trekkracht	270 kN		
Max. voorspanning	120 kN		
Max. werkdruk	350 bar	<b>Aggregaat:</b>	
Max. oliedoorstroming	340 l/min	Model	400 series
Max. hydraulisch vermogen	198/269 kW/PK		
Geforceerde smering	ja		
Dynamisch gewicht excl. 130TU	2130 kg	<b>Slangenset:</b>	
Dynamisch gewicht incl. 130TU	2740 kg	Lengte	30 m
Totaalgewicht excl. 130TU & slangen	2900 kg	Transportgewicht (±)	615 kg

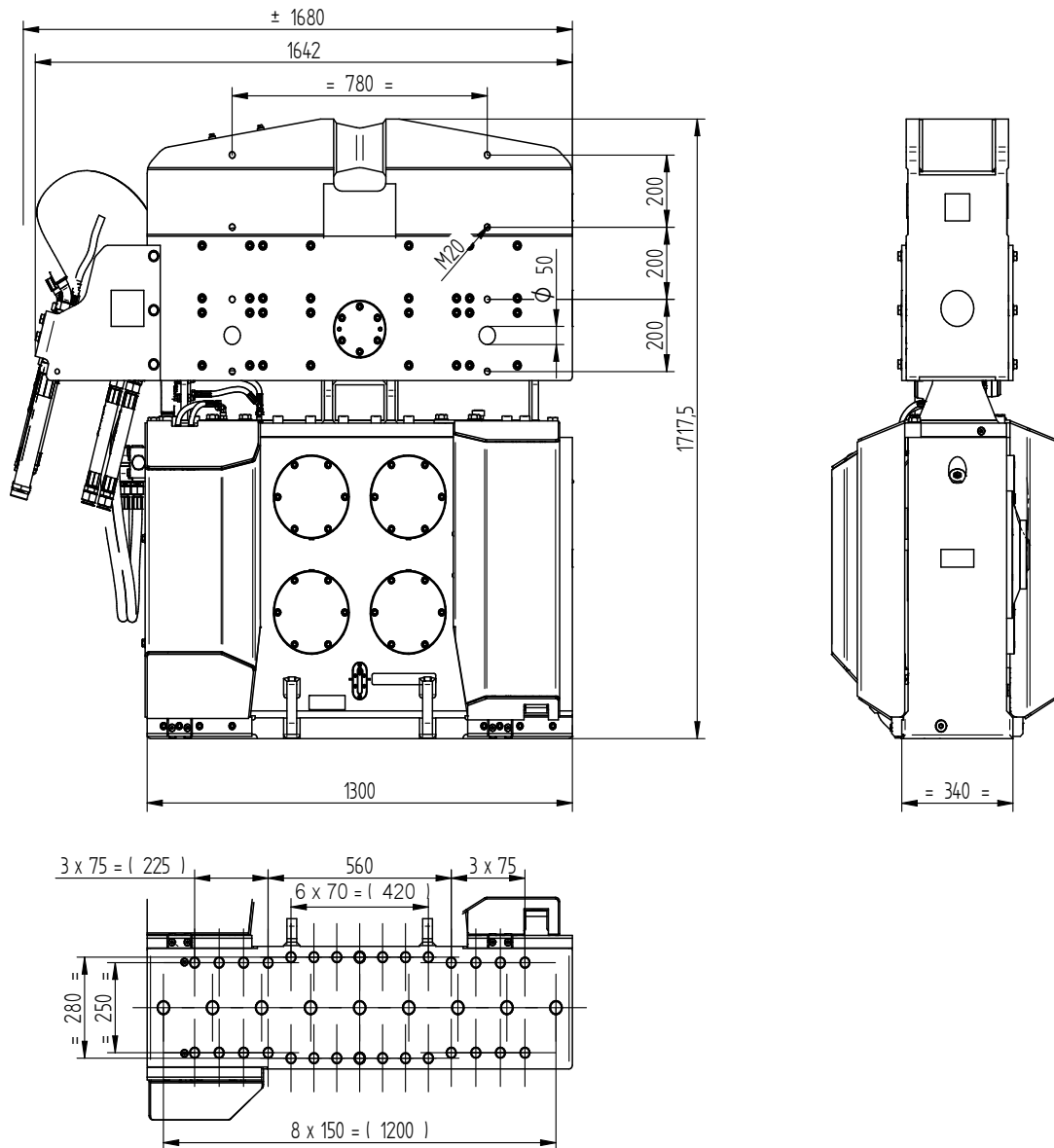

### Especificaciones

### ICE 15RF

Momento excéntrico	0-14,7 kgm	<b>Abrazadera:</b>	
Fuerza centrífuga máxima	0-870 kN	Hoja abrazadera pila	130TU
Frecuencia máxima	2300 rpm	Peso de transporte por pieza	610 kg
Amplitud máxima excluyendo 130TU	12,6 mm	Abrazadera de tubo	55TC
Amplitud máxima incluyendo 130TU	10,7 mm	Peso de transporte por pieza	310 kg
Estático tracción máxima	270 kN		
Compresión máxima	120 kN		
Presión máxima de trabajo	350 bar	<b>Unidad de potencia:</b>	
Flujo de aceite máximo	340 l/min	Modelo	400 series
Máxima potencia hidráulica	198/269 kW/HP		
Lubricación forzada	si		
Peso dinámico excluyendo 130TU	2130 kg	<b>Conjunto de manguera:</b>	
Peso dinámico incluyendo 130TU	2740 kg	Longitud	30 m
Peso total excluyendo 130TU & mangueras	2900 kg	Peso de transporte (±)	615 kg

Dimensions in inches

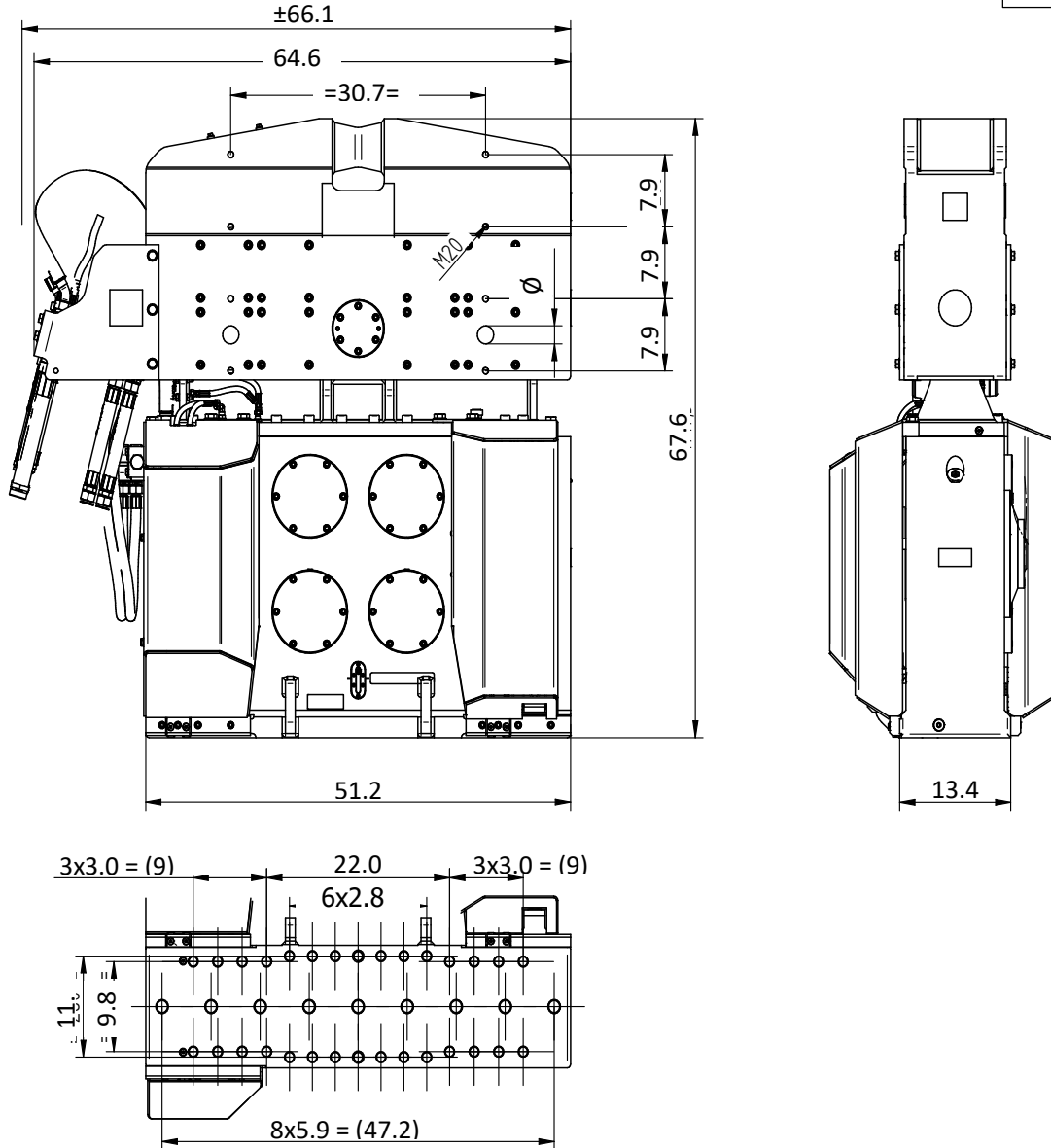

Specifications		ICE 15RF	
Eccentric moment	0-1,276 in-lbs	<b>Clamps:</b>	
Max. centrifugal force	0-98 ton	Sheet pile clamp	130TU
Max. frequency	2,300 rpm	Transport weight per piece	1,345 lbs
Max. amplitude excluding 130TU	0.5 in	Double clamps	55TC
Max. amplitude including 130TU	0.42 in	Transport weight per piece	683 lbs
Max. static line-pull	30 ton		
Max. pull-down	13 ton		
Max. operating pressure	5,076 psi	<b>Powerpack:</b>	
Max. oil flow	90 gal/min	Model	400 series
Max. hydraulic power	198/269 kW/HP		
Forced lubrication	yes		
Dynamic weight excluding 130TU	4,696 lbs	<b>Hose set:</b>	
Dynamic weight including 130TU	6,041 lbs	Length	98 ft
Total weight excluding 130TU & hoses	6,393 lbs	Transport weight (±)	1,356 lbs

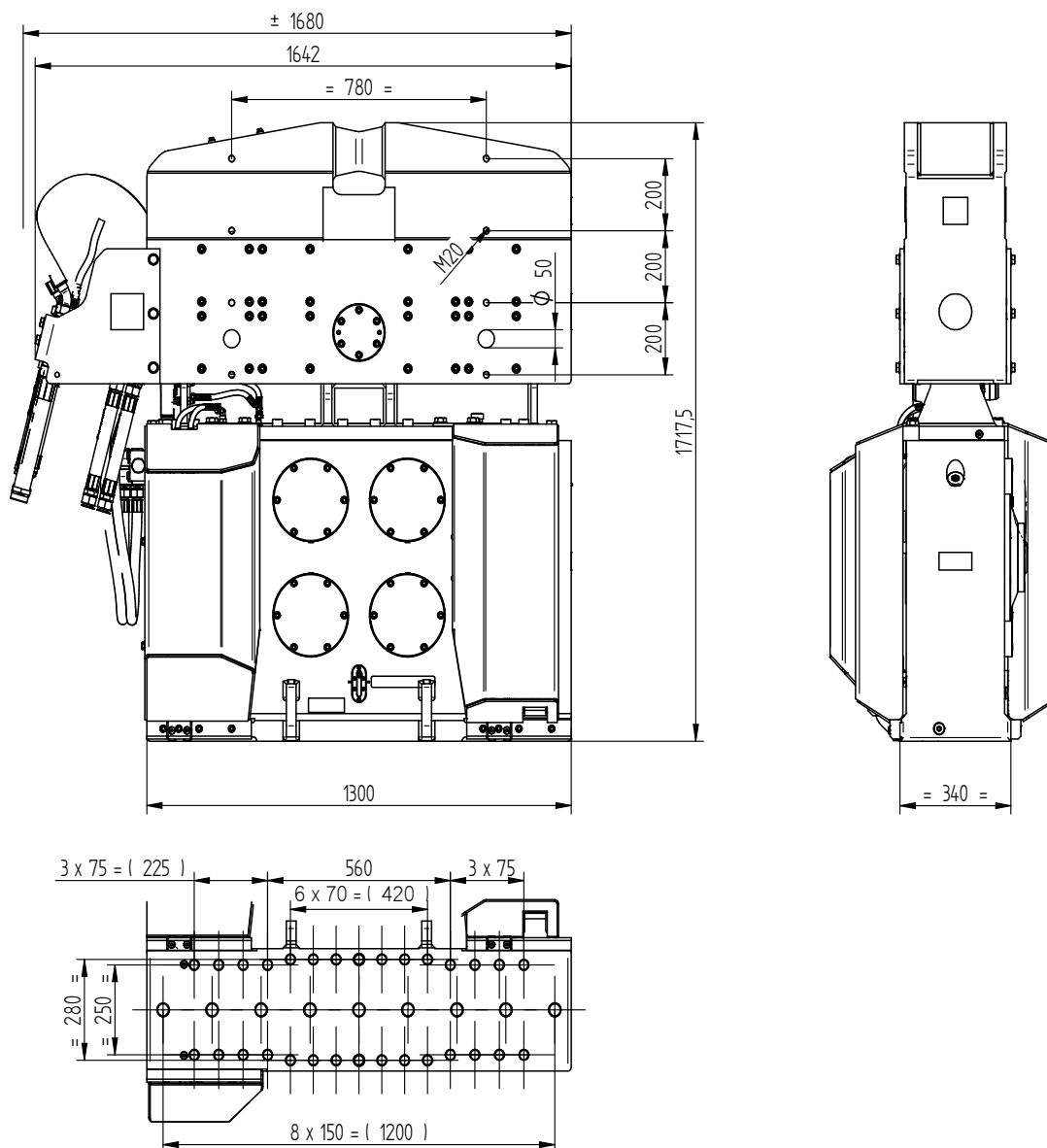

#### Specificatii :

#### ICE 15RF

Moment excentric	0-14,7 kgm	<b>menghira:</b>	
Forta centrifuga maxima	0-870 kN	menghina pentru palplanse	130TU
Frecventa maxima	2300 rpm	Greutatea de transport pp.	610 kg
Amplitudine maxima exclusiva. 130TU	12,6 mm	menghina dubla	55TC
Amplitudine maxima inclusivă. 130TU	10,7 mm	Greutatea de transport pp.	310 kg
Tractiune maxima statica	270 kN		
Trage în jos maxima	120 kN		
Presiune maxima de lucru	350 bar	<b>generatoare:</b>	
Debit maxim de ulei	340 l/min	Model	400 series
Puterea hidraulică maxima	198/269 kW/HP		
Lubrifiere fortata	da		
Greutatea dinamica exclusiva. 130TU	2130 kg	<b>Tip de furtun:</b>	
Greutatea dinamica inclusivă. 130TU	2740 kg	Lungimea	30 m
Greutatea totala fara. 130TU si furtun	2900 kg	Greutatea de transport (±)	615 kg