



Specification sheet

PVE 170M

Vibro Hammer

English

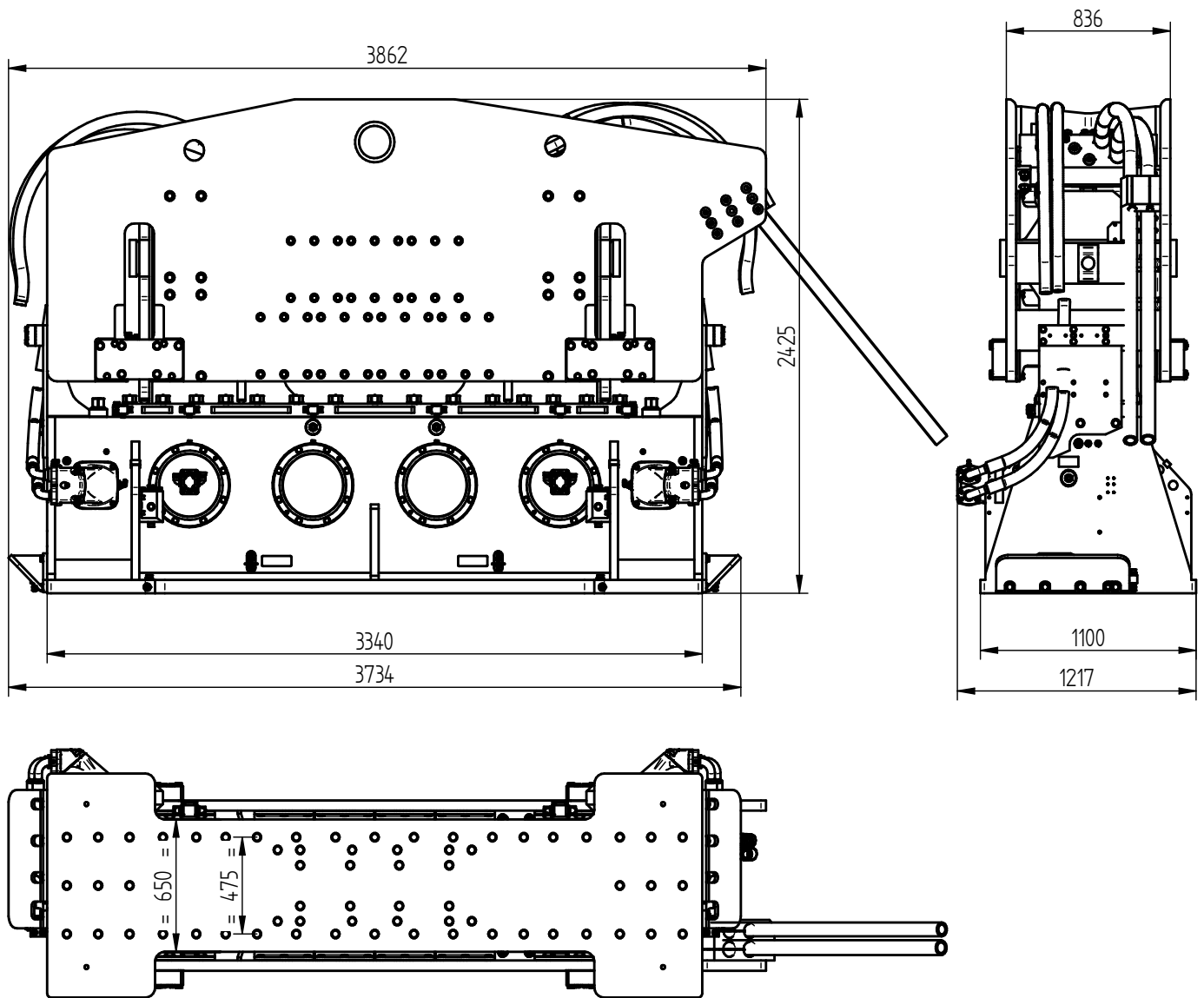

Specifications :

PVE 170M

Eccentric moment	170 kgm	Clamps:	
Centrifugal force	3654 kN	Double clamps	350TC (2x)
Max. frequency	1400 rpm	Transport weight per piece	2980 kg
Max. amplitude excl. 350TC (2x)	29,7 mm		
Max. amplitude incl. 350TC (2x)	19,5 mm		
Max. static line-pull	1260 kN		
Max. pull-down	120 kN		
Max. operating pressure	350 bar	Powerpack:	
Max. oil flow	1293 l/min	Model	1400 series
Max. hydraulic power	754/1025 kW/HP		
Forced lubrication	yes		
Dynamic weight excl. 350TC (2x)	11455 kg	Hose set:	
Dynamic weight incl. 350TC (2x)	17415 kg	Length	60 m
Total weight excl. 350TC (2x) & hoses	17850 kg	Transport weight (±)	1640 kg

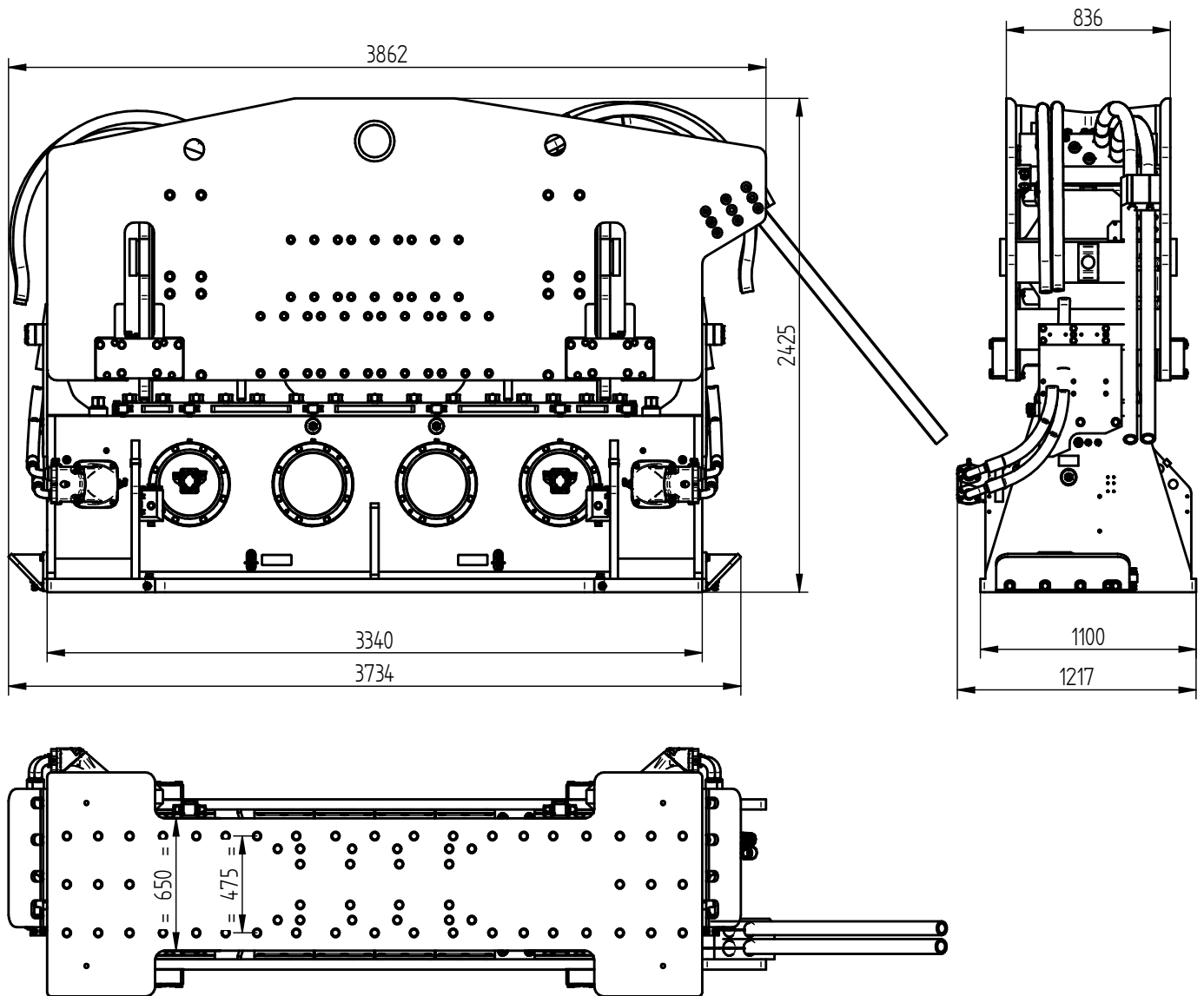

Technische Daten :

PVE 170M

Statisches Moment	170 kgm	Klemmzange:	
Max. Fliehkraft	3654 kN	Rohrklemmzange	350TC
Max. Drehzahl	1400 rpm	Transportgew. pro Stück	2980 kg
Max. Amplitude ohne 350TC (2x)	29,7 mm		
Max. Amplitude mit 350TC(2x)	19,5 mm		
Max. Statische Zugkraft	1260 kN		
Max. Vorspannung	120 kN		
Max. Betriebsdruck	350 bar	Aggregat:	
Max. Fördermenge	1293 l/min	Modell	1400 series
Max. hydraulische Leistung	754/1025 kW/PS		
Zwangsschmierung	ja		
Dyn. Gewicht ohne 350TC (2x)	11455 kg	Schlauchsatz:	
Dyn. Gewicht mit 350TC (2x)	17415 kg	Länge	60 m
Gesamtgew. ohne 350TC (2x) & Schläuche	17850 kg	Transportgewicht (±)	1640 kg



Spécifications

PVE 170M

Vibro Hammer

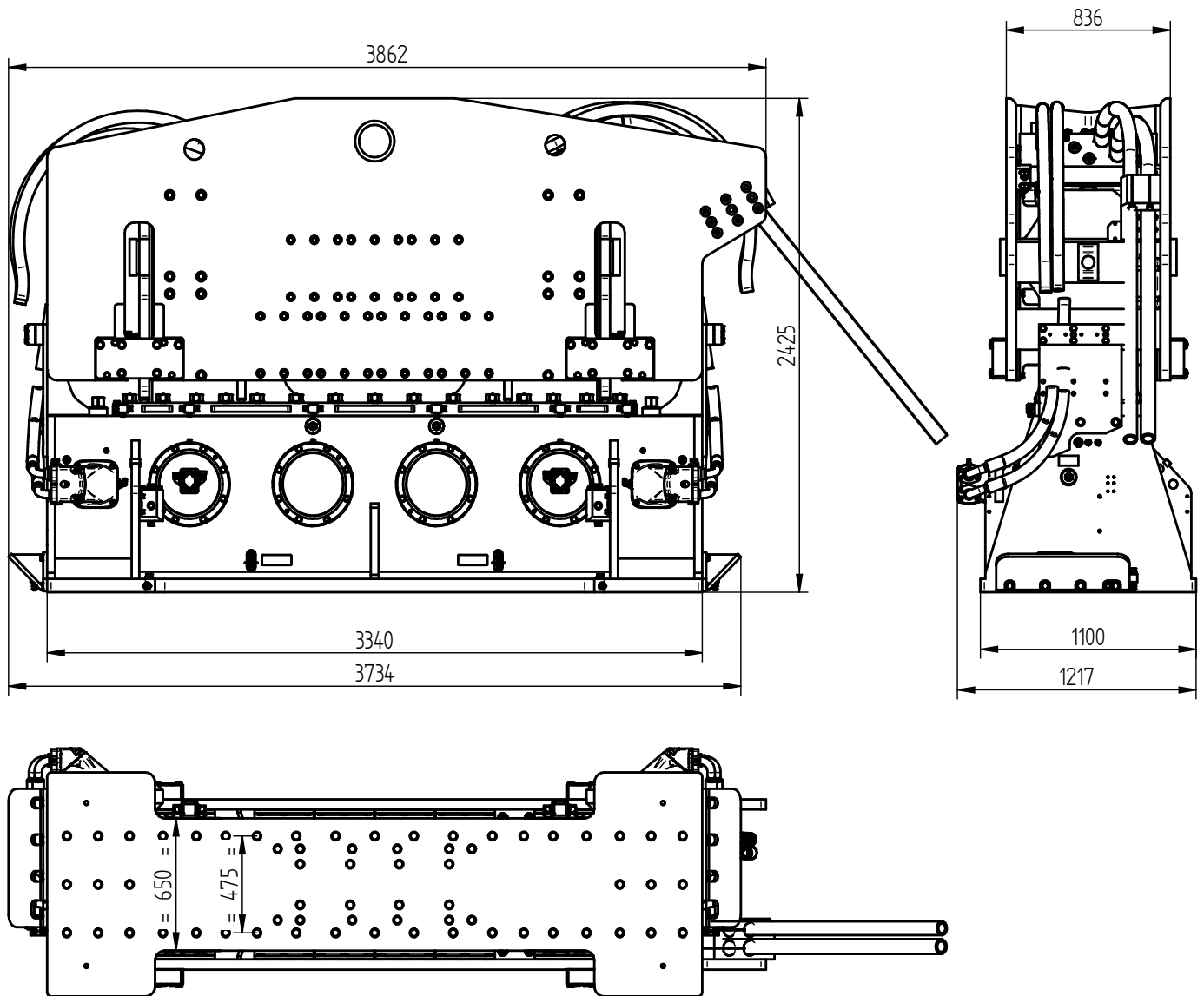

Spécifications

PVE 170M

Moment excentrique	170 kgm	Pinces:	
Max. force centrifuge	3654 kN	Pince tube	350TC
Max. fréquence	1400 rpm	Poids de transport par pièce	2980 kg
Max. amplitude sans 350TC (2x)	29,7 mm		
Max. amplitude avec 350TC (2x)	19,5 mm		
Force de traction statique	1260 kN		
Force maximale d'appui	120 kN		
Pression de travail max.	350 bar	Groupe hydraulique:	
Débit d'huile max.	1293 l/min	Modèle	1400 series
Puissance hydraulique max.	754/1025 kW/ch		
Huile lubrifiante	oui		
Poids dynamique sans 350TC (2x)	11455 kg	Jeu de tuyau:	
Poids dynamique avec 350TC (2x)	17415 kg	Longueur	60 m
Poids total sans 350TC (2x) & tuyaux	17850 kg	Poids de transport (±)	1640 kg



Specificaties

PVE 170M

Vibro Hammer

Nederlands

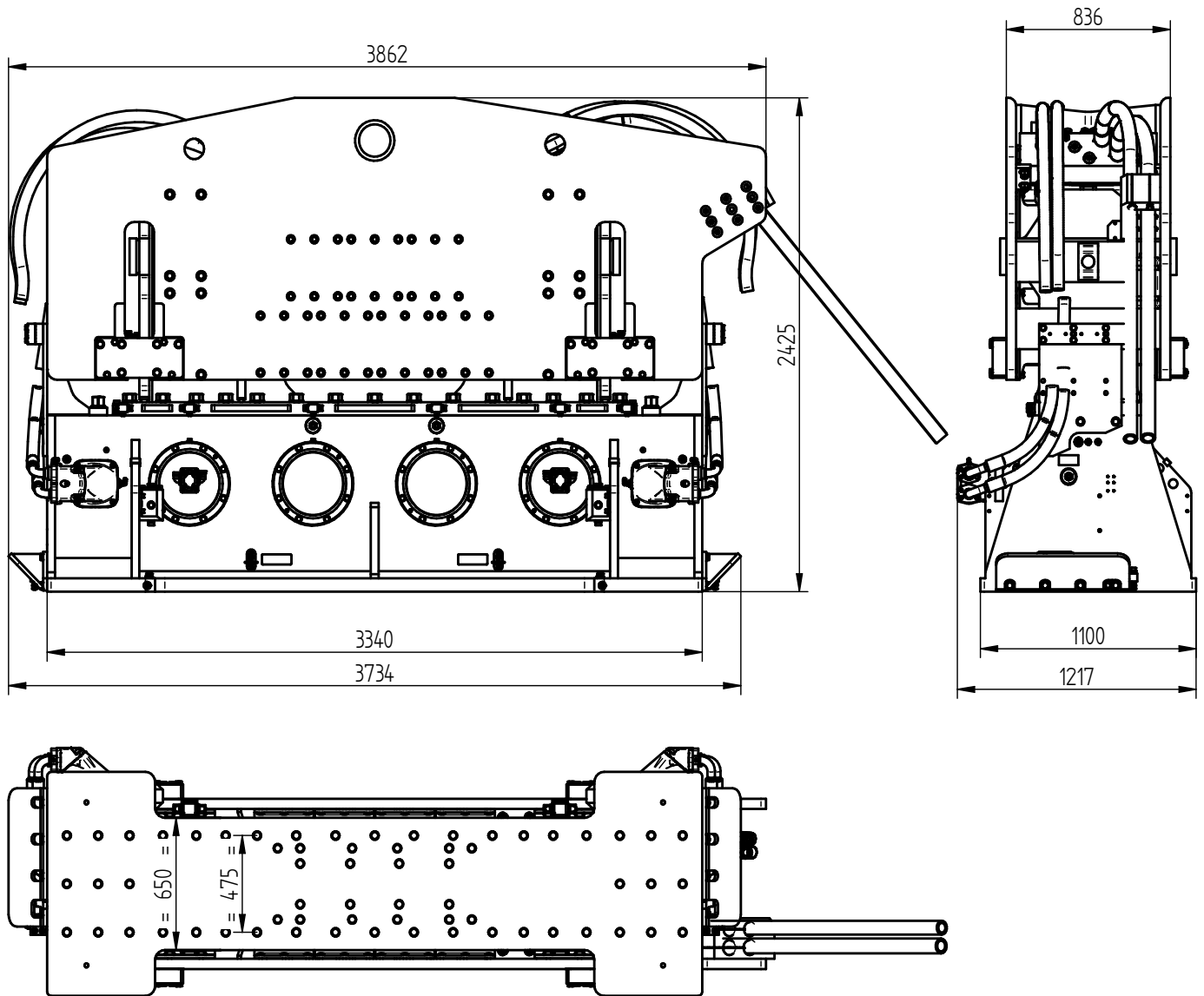

Specificaties

PVE 170M

Excentrisch moment	170 kgm	Klemmen:	
Max. centrifugaalkracht	3654 kN	Damwandklem	350TC
Max. toerental	1400 rpm	Transportgewicht per klem	2980 kg
Max. amplitude excl. 350TC (2x)	29,7 mm		
Max. amplitude incl. 350TC (2x)	19,5 mm		
Max. statische trekkracht	1260 kN		
Max. voorspanning	120 kN		
Max. werkdruk	350 bar	Aggregaat:	
Max. oliedoorstroming	1293 l/min	Model	1400 series
Max. hydraulisch vermogen	754/1025 kW/PK		
Geforceerde smering	ja		
Dynamisch gewicht excl. 350TC (2x)	11455 kg	Slangenset:	
Dynamisch gewicht incl. 350TC (2x)	17415 kg	Lengte	60 m
Totaalgewicht excl. 350TC (2x) & slangen	17850 kg	Transportgewicht (±)	1640 kg

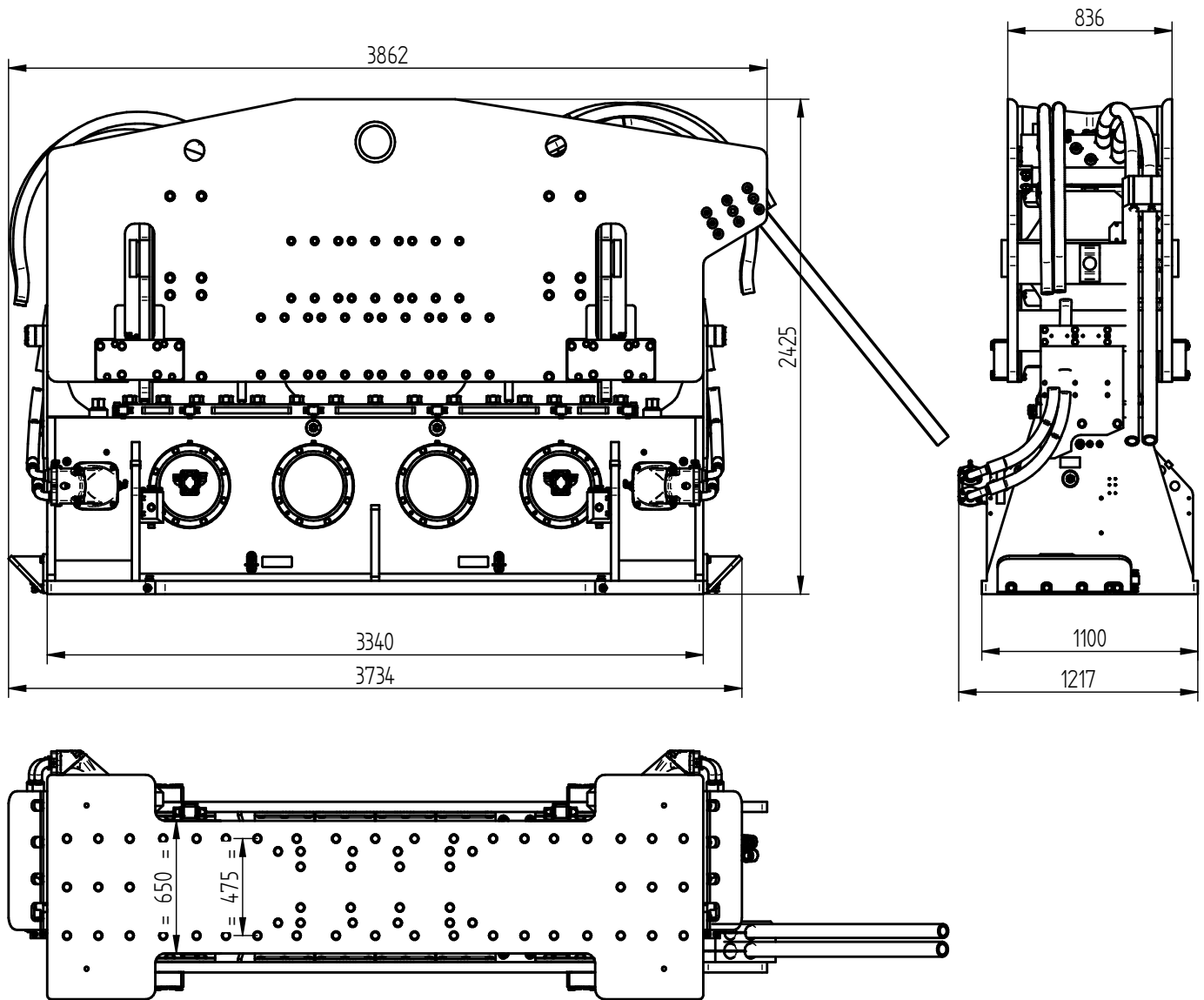

Especificaciones

PVE 170M

Momento excéntrico	170 kgm	Abrazadera:	
Fuerza centrífuga máxima	3654 kN	Abrazadera de tubo	350TC
Frecuencia máxima	1400 rpm	Peso de transporte por pieza	2980 kg
Amplitud máxima excluyendo 350TC (2x)	29,7 mm		
Amplitud máxima incluyendo 350TC (2x)	19,5 mm		
Estático tracción máxima	1260 kN		
Compresión máxima	120 kN		
Presión máxima de trabajo	350 bar	Unidad de potencia:	
Flujo de aceite máximo	1293 l/min	Modelo	1400 series
Máxima potencia hidráulica	754/1025 kW/HP		
Lubricación forzada	si		
Peso dinámico excluyendo 350TC (2x)	11455 kg	Conjunto de manguera:	
Peso dinámico incluyendo 350TC (2x)	17415 kg	Longitud	60 m
Peso total excluyendo 350TC (2x) & mangueras	17850 kg	Peso de transporte (±)	1640 kg



Specifications

PVE 170M

Vibro Hammer

USA

Dimensions in inches

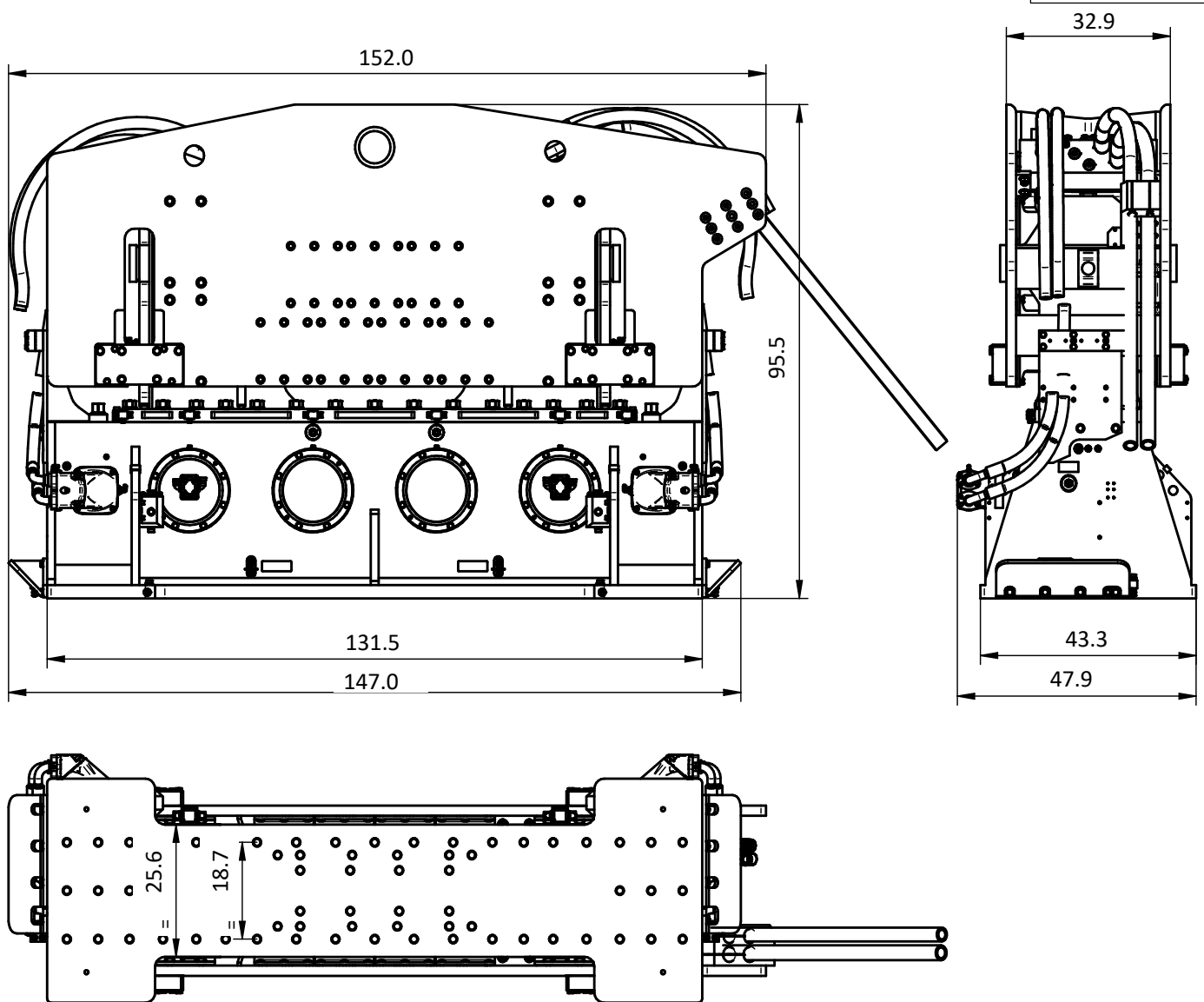

Specifications		PVE 170M	
Eccentric moment	14,757 in-lbs	Clamps:	
Centrifugal force	411 ton	Double clamps	350TC
Max. frequency	1,400 rpm	Transport weight per piece	6,570 lbs
Max. amplitude excluding 350TC (2x)	1.17 in		
Max. amplitude including 350TC (2x)	0.77 in		
Max. static line-pull	142 ton		
Max. pull-down	13 ton		
Max. operating pressure	5,076 psi	Powerpack:	
Max. oil flow	342 gal/min	Model	1400 series
Max. hydraulic power	754/1025 kW/HP		
Forced lubrication	yes		
Dynamic weight excluding 350TC (2x)	25,254 lbs	Hose set:	
Dynamic weight including 350TC (2x)	38,394 lbs	Length	197 ft
Total weight excluding 350TC (2x) & hoses	39,353 lbs	Transport weight (±)	3616 lbs



Specificatii

PVE 170M

Ciocan cu vibratii

românesc

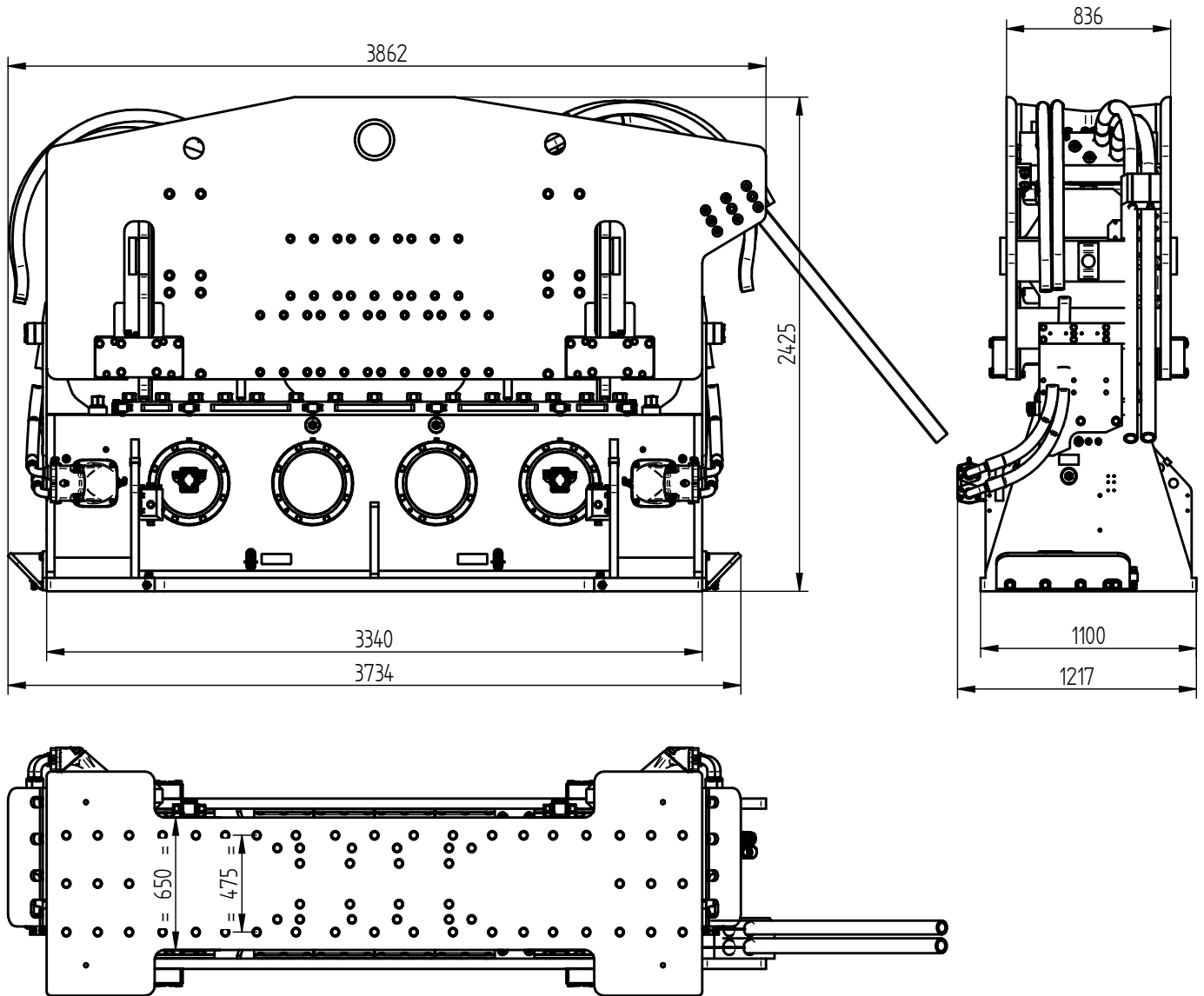

Specificatii :

PVE 170M

Moment excentric	170 kgm	menghira:	
Forta centrifuga maxima	3654 kN	menghina dubla	350TC
Frecventa maxima	1400 rpm	Greutatea de transport pp.	2980 kg
Amplitudine maxima exclusiva. 350TC (2x)	29,7 mm		
Amplitudine maxima inclusivă. 350TC (2x)	19,5 mm		
Tractiune maxima statica	1260 kN		
Trage în jos maxima	120 kN		
Presiune maxima de lucru	350 bar	generatoare:	
Debit maxim de ulei	1293 l/min	Model	1400 series
Puterea hidraulică maxima	754/1025 kW/HP		
Lubrifiere fortata	da		
Greutatea dinamica exclusiva. 350TC (2x)	11455 kg	Tip de furtun:	
Greutatea dinamica inclusivă. 350TC (2x)	17415 kg	Lungimea	60 m
Greutatea totala fara. 350TC (2x) si furtun	17850 kg	Greutatea de transport (±)	1640 kg